



GREAT PLAINS INDUSTRIES, INC.

"A Great Plains Ventures Subsidiary"

www.gpipumps.net
1-800-835-0113

M-3130 & M-3130-RDP Series 115/230 Volt Super Duty Fuel Pump

M-3130-ML Manual Nozzle
M-3130-AL Automatic Nozzle
M-3130-PO Pump Only

Owner's Manual

STOP

**DO NOT RETURN
THIS PRODUCT
TO THE STORE!**

Please contact GPI before returning any product. If you are missing parts or experience problems with your installation, our Customer Support Department will be happy to assist you.

**GPI Customer Support
800-835-0113 or
316-686-7361**

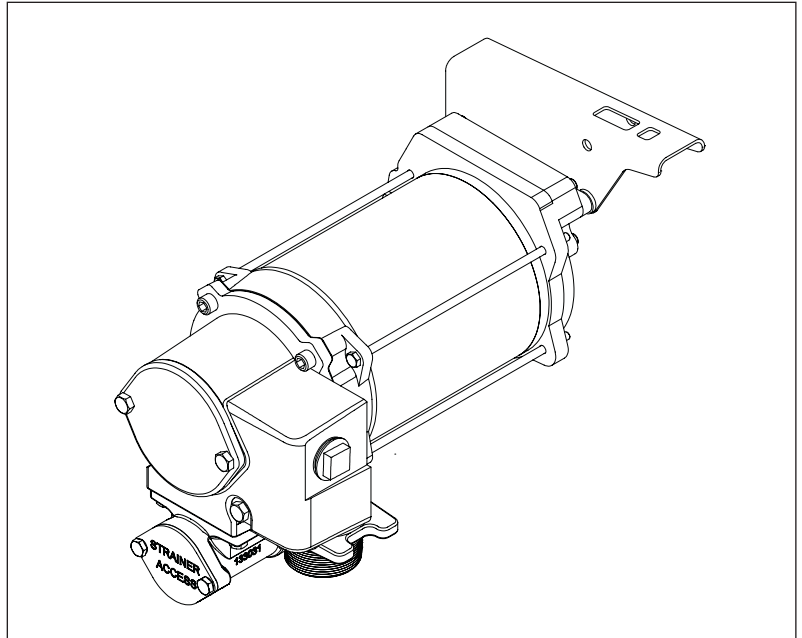

TABLE OF CONTENTS

General Information.....	2
Installation	2
Operation.....	4
Troubleshooting.....	5
Illustrated Parts Drawing	6
Specifications.....	7
Parts and Service	7

To the owner...

Congratulations on receiving your GPI Super Duty Fuel Pump. We are pleased to provide you with a system designed to give you maximum reliability and efficiency.

Your fuel pump is designed, tested, and approved for use with gasoline, kerosene, and diesel fuel. Please take all due precautions when handling these flammable liquids. Your safety is important to us.

Also, to assure the longest possible service life, it is important that you follow the operation and maintenance procedures outlined in this manual. We are proud to provide you with a quality product and dedicated support. Together with your conscientious use, we are sure that you will obtain years of safe, dependable service.



Great Plains Industries, Inc. is a member of
the Petroleum Equipment Institute.

President
Great Plains Industries, Inc.

GENERAL INFORMATION

Your pump is designed for use **only** with thin viscosity petroleum fuels such as gasoline (up to 15% alcohol blends such as E15), diesel fuel (up to 20% biodiesel blends such as B20) and kerosene. **Do not** use this pump for dispensing any fluids other than those for which it was designed. Using the pump with other fuels can damage components and void the warranty.

Model Components

M-3130-ML: Includes pump, hose, manual nozzle.

M-3130-AL: Includes pump, hose, automatic nozzle.

M-3130-PO: Includes pump only.

M-3130-RDP: Includes dedicated pump only for remote dispensing systems.

NOTE: Suffixes ML, AL and PO are for ordering purposes only. Constructions described above are covered as alternate constructions under the Part No. M-3130 UL Listing.

How to Use This Manual

The purpose of this manual is to assist you in installing, operating and maintaining your GPI pump. If you need additional assistance, contact your GPI dealer or the GPI Customer Service Department.



The following safety alert symbols are used in this manual. Obey all safety messages that follow this symbol to avoid possible injury or death.

DANGER

DANGER indicates an imminently hazardous situation which, if not avoided, will result in death or serious injury.

WARNING

WARNING indicates a potentially hazardous situation which, if not avoided, could result in death or serious injury.

CAUTION

CAUTION indicates a potentially hazardous situation which, if not avoided, may result in minor or moderate injury.

CAUTION

CAUTION used without the safety alert symbol indicates a potentially hazardous situation which, if not avoided, may result in property damage.

There are inherent dangers wherever flammable fuel and AC electrical sources are in close proximity.

Static electricity as a source of sparking is always a concern and requires extreme care in the installation and operation of your entire fuel transfer system.

Additional components such as meters, automatic nozzles and filters must be listed for use with fuel transfer systems. The flow of fuel through a hose and nozzle can generate static electrical charges and dangerous sparking can result in fire or explosion. Hoses and nozzles must be electrically conductive and bonded to ground.

It is your responsibility to:

- Know and follow applicable national, state and local safety codes pertaining to installing and operating electrical equipment for use with flammable liquids.
- Know and follow all safety precautions when handling petroleum fuels.
- Ensure that all equipment operators have access to adequate instructions concerning safe operating and maintenance procedures.



INSTALLATION

Mechanical Connections

WARNING

Coverplates protect the operator from moving parts. Never operate the pump without coverplates in place. Never apply electric power to the pump without coverplates in place. Always disconnect power before repairing or servicing.

All threaded fuel connections must be sealed with thread tape or a pipe thread sealing compound approved for use with petroleum fuels.

Your pump must be mounted on a vented tank. If the tank is not vented, contact your GPI distributor for the correct vent cap.

This pump has a built-in check valve to keep the pump primed. No additional check valve is required on suction pipes shorter than 15 feet (4.6 meters). Make sure any check valves or foot valves used are equipped with proper pressure relief valves.

Your pump is designed to mount directly to a standard 2-inch female tank fitting. For the suction pipe, a 1-1/4-inch galvanized steel pipe cut to length and threaded on one end may be used. Suction pipe should extend to within 3 inches of tank bottom. Apply thread tape to the suction pipe thread and securely tighten the suction pipe to the pump inlet port.

Install Nozzle Hanger (Not applicable to pumps with -RDP suffix)

Attention: The nozzle hanger for your pump was removed before shipping to protect against damage.

To reinstall the nozzle hanger follow the steps below.

1. Remove the two (2) 1/4"-20 x 1/2" bolts and the two (2) flat washers from the switch coverplate.

- Place the two bolts through the nozzle cover and then place the two flat washers on the bolts. The washers are used as spacers to set the nozzle hanger away from the switch coverplate.
- Align the bolts with the two threaded holes on the switch coverplate thread the bolts into the holes. Torque bolts to 45-60 in/lb (Figure 1).

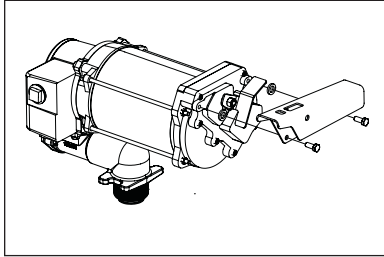

Figure 1

Switch Locking Lever

Attention: The M-3130-RDP remote dispenser pump incorporates an external switch locking lever that locks the pump switch in the “ON” position. The pump is typically shut off using the remote dispensing device “ON-OFF” mechanism.

Electrical Connections

⚠ DANGER

Pump must be installed by a licensed electrician and conform to National Fire Protection Association (NFPA) codes 30 and 70. You, as the owner, are responsible for seeing that the installation and operation of your pump complies with NFPA codes as well as any applicable state and local codes. Rigid conduit must be used to install wiring.

Failure to follow these wiring instructions may result in death or serious injury from shock, fire or explosion.

The pump must be properly grounded to avoid personal injury. Operating an ungrounded or improperly grounded pump may result in death due to electrical shock, fire or explosion.

Electrical wiring and connections must be made only by a licensed electrician in accordance with national, state and local electrical codes regarding Class I, Division 1, Group D locations. Other codes may apply.

Thread for the conduit connection at the pump electrical box is 1/2 inch FNPT.

A standard 15-amp breaker is recommended.

This pump is equipped with an auxiliary AC accessory lead. The third wire (red) is to be used to energize a control circuit that operates a device such as a signal light or a solenoid operated valve. Maximum amp draw on the control circuit is 1 amp. If you do not need this feature, insure that the wire is insulated and enclosed within the electrical cavity of the pump.

⚠ CAUTION

Connect pump to the proper voltage source. M-3130 series pumps are designed to operate on 115 VAC, 60 HZ or 230 VAC, 60 HZ. Connection to improper voltage will damage pump. Pump is set at factory for low voltage (115-volt). For high voltage applications (230-volt) see wiring diagram located inside electrical coverplate.

Wiring Details

- Remove electrical coverplate (Figure 2). Install conduit and cable from switchbox to pump electrical box. Wiring must be in accordance with Class I, Division 1 requirements in the applicable national electrical code.

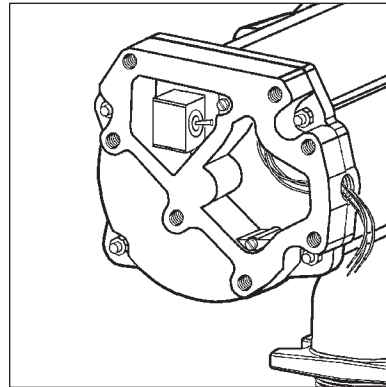

Figure 2

- Attach ground wire using the green ground screw located inside the electrical box (Figure 3). Connect the power cable to the pump wiring per the wiring diagram located inside the electrical coverplate. Secure with wire nuts.

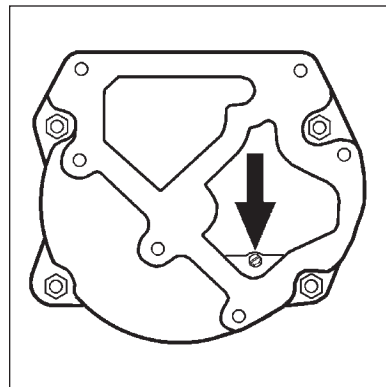

Figure 3

- Position wires inside the electrical box. Replace electrical coverplate with all seven (7) screws and tighten securely.

OPERATION

⚠ DANGER

To prevent physical injury, observe precautions against fire or explosion when dispensing fuel. Do not operate the system in the presence of any source of ignition including running or hot engines, lighted cigarettes, or gas or electric heaters.

⚠ WARNING

Observe precautions against electrical shock when operating the system. Serious or fatal shock can result from operating electrical equipment in damp or wet locations.

⚠ CAUTION

Avoid prolonged skin contact with petroleum fuels. Use protective goggles, gloves, and aprons in case of splashing or spills. Change saturated clothing and wash skin promptly with soap and water.

To dispense fuel (for pumps with nozzle hanger):

1. Remove the nozzle from the holder. Turn the pump on by pulling the switch lever down.
2. Insert the nozzle into the receiving tank and squeeze the handle to dispense fuel.
3. After dispensing fuel, push the switch lever up to turn the pump off and return the nozzle to the holder. The nozzle may be locked in place to prevent unauthorized use.

The pump contains an automatic bypass valve to prevent pressure buildup when the pump is on but the nozzle is closed. Do not leave the pump on for more than 10 minutes with the nozzle closed.

Never leave the pump running without fluid. Dry running can damage the pump components.

The pump has a duty cycle of 30 minutes ON and 30 minutes OFF. Do not overheat. Allow the motor to cool the same length of time it was in operation.

The fuel strainer and check valve assembly should be cleaned on a regular basis or if low flow rate is noticed.

If the pump becomes too hot, an internal temperature-limiting device will automatically shut the motor off and prevent operation until it cools.

⚠ CAUTION

Always turn the pump off if the temperature-limiting device trips. The Remote Dispenser pump (M-3130-RDP) turns off at the dispensing device. If left on, the pump will automatically reset when cool and start pumping.

TROUBLESHOOTING

SYMPTOM	PROBABLE CAUSE	CORRECTIVE ACTION
A. MOTOR DOES NOT RUN	<ol style="list-style-type: none"> 1. No electrical power to pump 2. Auxiliary temperature-limiting device tripped 3. Rotor or vanes jammed 	<p>Check breaker, switchbox and wiring.</p> <p>Allow motor to cool. Auxiliary temperature-limiting device will automatically reset.</p> <p>Remove coverplate and check for damage or obstruction.</p>
B. MOTOR RUNS, BUT NO FLOW	<ol style="list-style-type: none"> 1. Tank level low 2. Clogged filter assembly 3. Clogged or broken suction pipe 4. Broken shaft key 	<p>Add fuel to tank.</p> <p>Remove and clean filter assembly.</p> <p>Remove pump and clear suction pipe, replace as needed.</p> <p>Replace shaft key. Check rotor or vanes for obstruction.</p>
C. PUMP FAILS TO PRIME	<ol style="list-style-type: none"> 1. Air leak in system 2. Bypass valve stuck open 3. Check valve stuck open 4. Rotor or vanes worn 	<p>Check for air leaks at all joints.</p> <p>Remove bypass valve and clean or replace as needed.</p> <p>Remove check valve and clean or replace as needed.</p> <p>Check rotor and vanes for excessive wear.</p>
D. LOW FLOWRATE	<ol style="list-style-type: none"> 1. Low voltage 2. Clogged filter assembly 3. Air leak in system 4. Bypass valve stuck open 5. Rotor or vanes worn 6. Outlet is blocked 7. Clogged or broken suction pipe 	<p>Check incoming line voltage.</p> <p>Clean filter assembly.</p> <p>Check for air leaks at all joints.</p> <p>Remove bypass valve and clean or replace as needed.</p> <p>Check rotor and vanes for excessive wear.</p> <p>Check all accessories for blockage.</p> <p>Remove pump and clear suction pipe, replace as needed.</p>
E. MOTOR STALLS WHEN NOZZLE IS CLOSED	<ol style="list-style-type: none"> 1. Bypass valve stuck closed 2. Rotor or vanes worn 3. Low voltage 	<p>Remove bypass valve and clean or replace as needed.</p> <p>Check rotor and vanes for excessive wear.</p> <p>Check incoming line voltage.</p>
F. FUEL LEAKAGE	<ol style="list-style-type: none"> 1. Threaded joint loose 2. Insufficient bolt torque 3. Lost or damaged O-rings 4. Shaft seal worn or damaged 	<p>Check and reseal threaded joint.</p> <p>Retighten bolts.</p> <p>Check O-rings for damage. Replace as needed.</p> <p>Fuel leaking from drain hole indicates shaft seal needs to be replaced.</p>
G. MOTOR OVERHEATS	<ol style="list-style-type: none"> 1. Pumping high viscosity fluids 2. Clogged filter assembly 3. Clogged or broken suction pipe 	<p>Pump only low viscosity fluids.</p> <p>Clean filter assembly.</p> <p>Remove pump and clear suction pipe, replace as needed.</p>

ILLUSTRATED PARTS DRAWING

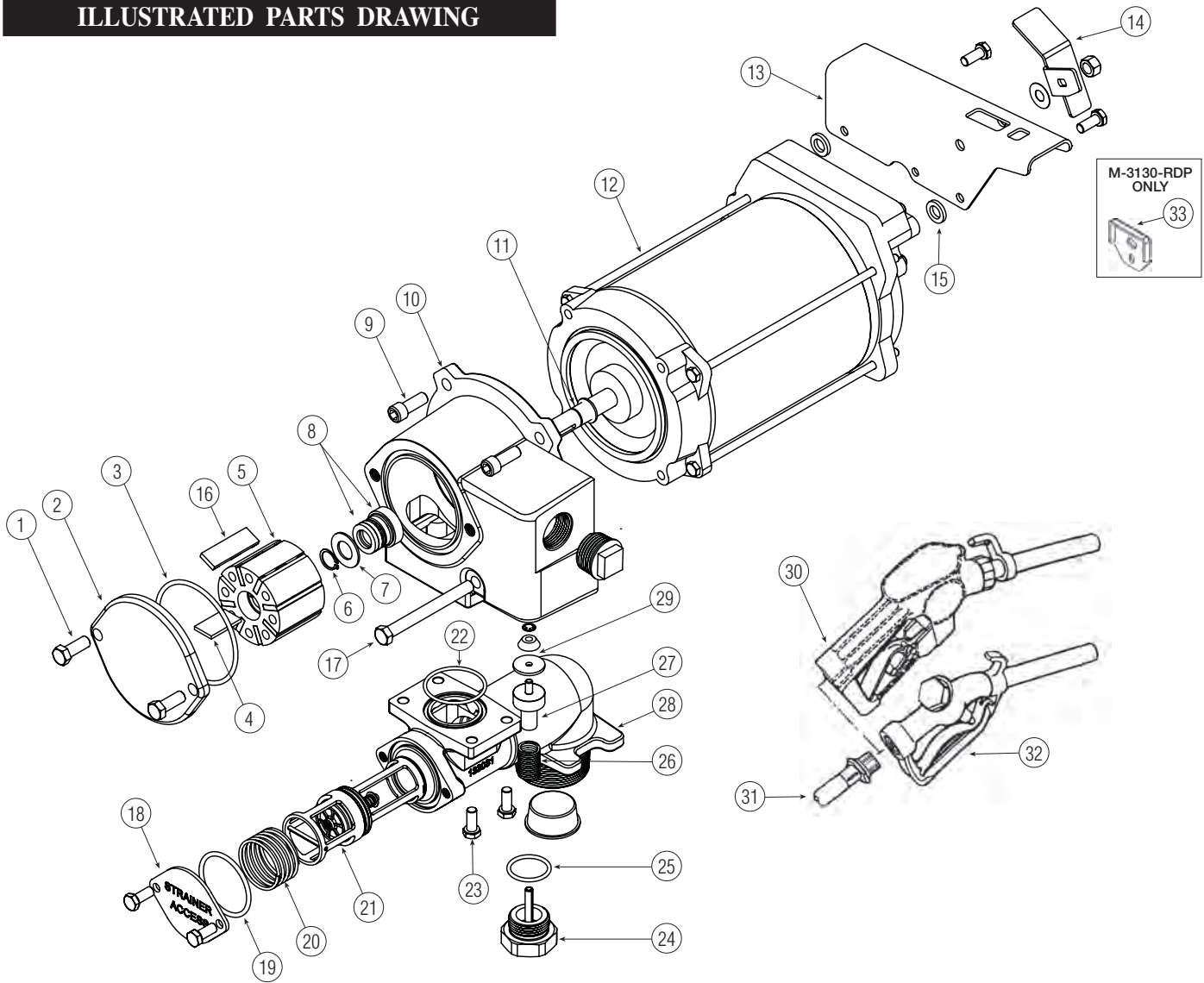

Item No.	Part No.	Description	No. Req'd.
1	904006-38	Hex Head Screw 3/8 - 16 x 1	2
2	133032-02	Coverplate	1
3	901003-15	O-Ring (or Kit C).....	1
4	121010-11	Shaft Key (or Kit A).....	1
5	133041-1	Rotor.....	1
6	904006-33	Retaining Ring (or Kit B).....	4
7	133027-1	Spacer Washer (or Kit B).....	1
8	906006-53	Shaft Seal (or Kit B).....	1
9	904006-54	Socket Head Screw 3/8 - 16 x 1	3
10	133039-03	Housing	1
11	133026-1	Slinger Washer	1
12	133521-01	Spares, Motor, 3/4 HP, 115/230 V	1
13	13312401	Nozzle Cover	1
14	13312301	Switch Lever.....	1
15	904006-57	Spacer Washer.....	2
16	133042-1	Vanes (or Kit A)	8
17	904006-49	Hex Head Screw 3/8 - 16 x 3-3/4	1

Item No.	Part No.	Description	No. Req'd.
18	133033-1	Base End Plate	1
19	901001-90	O-Ring (or Kit C).....	1
20	121019-1	Spring	1
21	121013-1	Check Valve Assembly	1
22	901002-89	O-Ring (or Kit C).....	1
23	904001-37	Hex Head Screw 5/16 - 18 x 3/4	8
24	133059-02	Poppet Plug.....	1
25	901002-50	O-Ring (or Kit C).....	1
26	133064-1	Poppet Spring	1
27	904004-89	Spring Pin.....	1
28	133031-06	Base	1
29	133505-01	Poppet Assembly Kit.....	1
30	906005-1	1" NPT Automatic Nozzle.....	1
31	121036-1	Hose Assembly, 1" x 12'	1
32	906001-10	1" NPT Manual Nozzle	1
33	133419-02	Switch Locking Lever	1

Kits and Accessories

- A** 133502-1 Vane Kit – O-Ring, 2-inch vanes, shaft key
- B** 133503-1 Shaft Seal Kit – Retaining ring, shaft seal, spacer washer
- C** 133504-1 Seal Kit
- 133052-02 Spares, Base Assembly
- 133534-01 Kit, Switch, M-3130/M-3295

SPECIFICATIONS

The M-3130 fuel pump is designed to safely transfer low viscosity petroleum fuels such as gasoline (up to 15% alcohol blends such as E15), diesel fuel (up to 20% biodiesel blends such as B20) and kerosene. The pump is designed for permanent mounting on vented storage tanks, either in-ground or above-ground. *RAINPROOF* for outdoor use.

Performance

Pump Rate:	Up to 30 GPM (114 LPM)
Duty Cycle:	30 minutes ON, 30 minutes OFF
Dry Prime:	15 ft. (4.6 m) maximum
Discharge Lift:	10 ft. (3 m) maximum

Operating Temperature

-20° F to +125° F (-29° C to +52° C)

Operating Pressure

25 PSI

Electrical

Input:	Factory set at 115 VAC, 60 Hz. Optional to set at 230 VAC, 60 Hz.
Conduit:	1/2 inch FNPT
Current Draw:	9.8 amps at full load (at 115 VAC, 60 Hz)
Motor:	3/4 HP, 1725 RPM induction type provided with an internal auxiliary temperature-limiting device

Mechanical Connections

Bung:	2 inch MNPT
Inlet:	1-1/4 inch FNPT
Outlet:	1 inch FNPT

Accessories

Hose:	1 in. x 12 ft. (3.7m) Buna-N electrically conductive
Nozzle:	1 in. manual leaded spout or 1 in. automatic diesel
Security:	Nozzle can be padlocked

Ship Weight	69 lbs. (31 kg) - Pump only
	77 lbs. (35 kg) - With manual nozzle
	79 lbs. (36 kg) - With automatic nozzle

PARTS AND SERVICE

In order to preserve the UL Listing for pump safety, return the entire pump to the factory for repair or replacement. For products serviced outside the factory, the UL nameplates must be defaced to indicate that the equipment may no longer meet the requirements for UL Listing. This does not apply to products serviced outside the factory under the UL program for Rebuilt Motors for Use in Hazardous Locations.

For warranty consideration, parts, or other service information, please contact your local distributor. If you need further assistance, contact the GPI Customer Service Department in Wichita, Kansas, during normal business hours. A toll free number is provided for your convenience.

1-800-835-0113

To obtain prompt, efficient service, always be prepared with the following information:

1. The model number of your pump.
2. The manufacturing date code of your pump.

For the M-3130 series, the date code is located on the motor nameplate.

For warranty work, always be prepared with your original sales slip or other evidence of purchase date.

Please contact GPI before returning any pump. It may be possible to diagnose the trouble and find a solution with a telephone call. GPI can also inform you of any special requirements you will need to follow for shipping.

CAUTION

Do not return the pump without authority from the Customer Service Department. Due to strict government regulations, GPI cannot accept pumps unless they have been drained and cleaned.

SAVE THESE INSTRUCTIONS

Limited Warranty Policy

Great Plains Industries, Inc. 5252 E. 36th Street North, Wichita, KS USA 67220-3205, hereby provides a limited warranty against defects in material and workmanship on all products manufactured by Great Plains Industries, Inc. This product includes a 2 year warranty from date of purchase as evidenced by the original sales receipt. A 30 month warranty from product date of manufacture will apply in cases where the original sales receipt is not available. Reference product labeling for the warranty expiration date based on 30 months from date of manufacture. Manufacturer's sole obligation under the foregoing warranties will be limited to either, at Manufacturer's option, replacing or repairing defective Goods (subject to limitations hereinafter provided) or refunding the purchase price for such Goods theretofore paid by the Buyer, and Buyer's exclusive remedy for breach of any such warranties will be enforcement of such obligations of Manufacturer. The warranty shall extend to the purchaser of this product and to any person to whom such product is transferred during the warranty period.

This warranty shall not apply if:

- A. the product has been altered or modified outside the warrantor's duly appointed representative;
- B. the product has been subjected to neglect, misuse, abuse or damage or has been installed or operated other than in accordance with the manufacturer's operating instructions.

To make a claim against this warranty, contact the GPI Customer Service Department at 316-686-7361 or 800-835-0113. Or by mail at:

Great Plains Industries, Inc.
5252 E. 36th St. North
Wichita, KS, USA 67220-3205

GPI will step you through a product troubleshooting process to determine appropriate corrective actions.

GREAT PLAINS INDUSTRIES, INC., EXCLUDES LIABILITY UNDER THIS WARRANTY FOR DIRECT, INDIRECT, INCIDENTAL AND CONSEQUENTIAL DAMAGES INCURRED IN THE USE OR LOSS OF USE OF THE PRODUCT WARRANTED HEREUNDER.

The company herewith expressly disclaims any warranty of merchantability or fitness for any particular purpose other than for which it was designed.

This warranty gives you specific rights and you may also have other rights which vary from U.S. state to U.S. state.

Note: In compliance with MAGNUSON MOSS CONSUMER WARRANTY ACT – Part 702 (governs the resale availability of the warranty terms).



POWER OPERATED
PUMP FOR PETROLEUM
PRODUCTS



MOTOR FOR
HAZARDOUS LOCATIONS



5252 East 36th Street North
Wichita, KS USA 67220-3205
TEL: 316-686-7361
FAX: 316-686-6746

GREAT PLAINS INDUSTRIES, INC.

"A Great Plains Ventures Subsidiary"

www.gpipumps.net

1-800-835-0113

GPI is a registered trademark of Great Plains Industries, Inc.

© 2011 GREAT PLAINS INDUSTRIES, INC., Wichita, KS
Printed in U.S.A.